



SMB Direct RDMA: 40GbE iWARP vs 56G Infiniband on Windows Server 2012 R2

Chelsio T5 40 Gb/sec Ethernet vs Mellanox ConnectX-3 56Gb/sec Infiniband Adapters

We compare the Chelsio T5 Unified Wire Network Adapters with the Mellanox ConnectX-3 Adapters for performance over the range of I/O sizes. Using a Chelsio T580-LP-CR 2 port 40 Gb Unified Wire Network adapter, Windows Server 2012 R2 can move data at **4.9** Gigabytes per second. Using a Mellanox MCX35A-FCBT 1 port Infiniband adapter, Windows Server 2012 R2 can move data at **5.6** Gigabytes per second. This means that Ethernet can now do RDMA performance without the need for specialized equipment.

The Topology

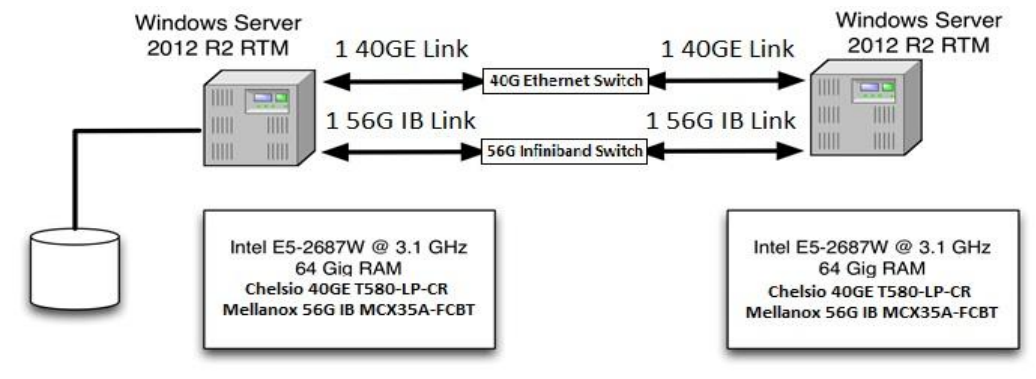

Network configuration: Two Microsoft Windows Server 2012 R2 machines dual connected through a 40Gb switch using a pair of Chelsio T580-LP-CR Unified Wire Adapters and a 56G IB switch using a pair of Mellanox MCX35A-FCBT Infiniband Adapters.

Software configuration: Each server is running a copy of Microsoft Windows Server 2012 R2 RTM. The benchmarking tool in use is sqlio2 from Microsoft. This tool is available from go.microsoft.com.

I/O benchmarking configuration: **Sqllo** is used to determine the I/O capacity of a configuration. For this demonstration, we use 4 sample block sizes: 8 KB, 32 KB, 128KB, and 512 KB. Buffering is set to none, and the I/O access pattern is random.

Server configuration: In order to demonstrate the full capacity of the Chelsio interface as well as the Windows operating environment, the target disk for this activity is a essentially a null disk where all data is discarded. Four RDMA connections are used.

Chelsio 40G Ethernet SMB Direct using RDMA iWARP

Block Size	IOs per second	Transfer Rate Gb/sec	% CPU on server
8k	552148	39	70%
32k	141271	39	21%
128k	35481	39	9%
512k	8866	39	7%

Mellanox 56G IB SMB Direct using RDMA Infiniband

Block Size	IOs per second	Transfer Rate Gb/sec	% CPU on server
8k	601872	45	80%
32k	170372	45	26%
128k	41871	45	11%
512k	9322	45	9%

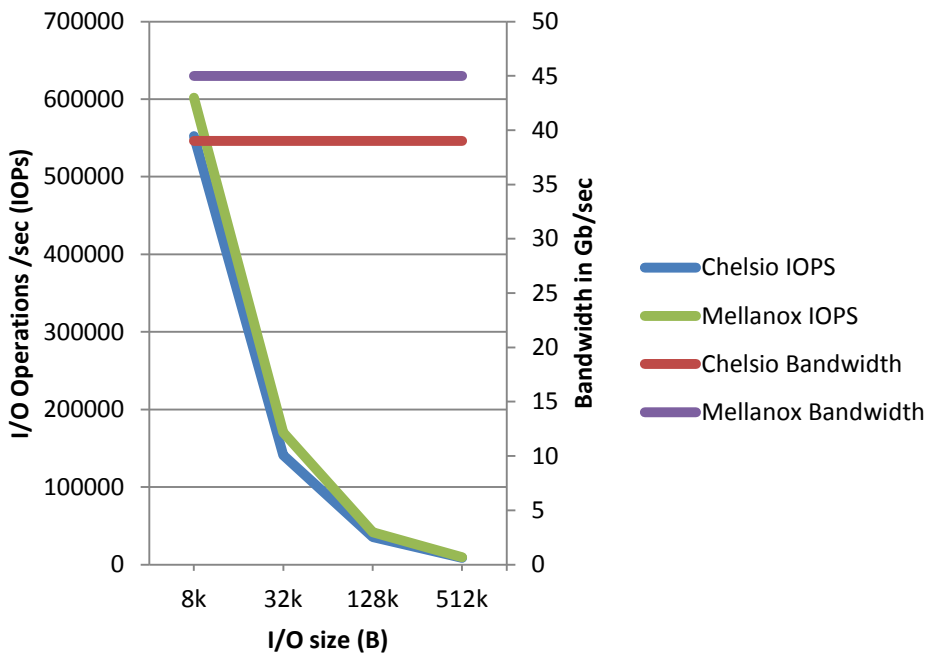

About Chelsio Communications

Chelsio is a leading technology company focused on providing high performance networking and storage solutions for virtualized enterprise data centers, cloud service installations, and cluster computing environments. Now shipping its fifth generation protocol acceleration technology, Chelsio is delivering hardware and software solutions including Unified Wire Ethernet network adapter cards, Unified Storage Server software, high performance storage gateways, unified management software, bypass cards, and other solutions focused on specialized applications.